



THERMO KIT

Recover your compressor's energy to supplement your central heating system

The Atlas Copco Thermo Kit is the simplest and most efficient way to recover the heat generated by your compressor and use it as a source of energy for your central heating system. The energy recovered from the compressor is used to heat water which is stored in a buffer vessel connected to the central heating system. The Thermo Kit is available with two vessel sizes – 400 or 800 liters – depending on the size of your compressor. Thermo Kit has been designed for general domestic and office central heating systems.

- Highly efficient energy recovery
- No direct contact between compressor and central heating system
- Possibility to store energy
- Easy, quick installation requires no engineering
- Hot water temperature controlled by Elektronikon®

Atlas Copco

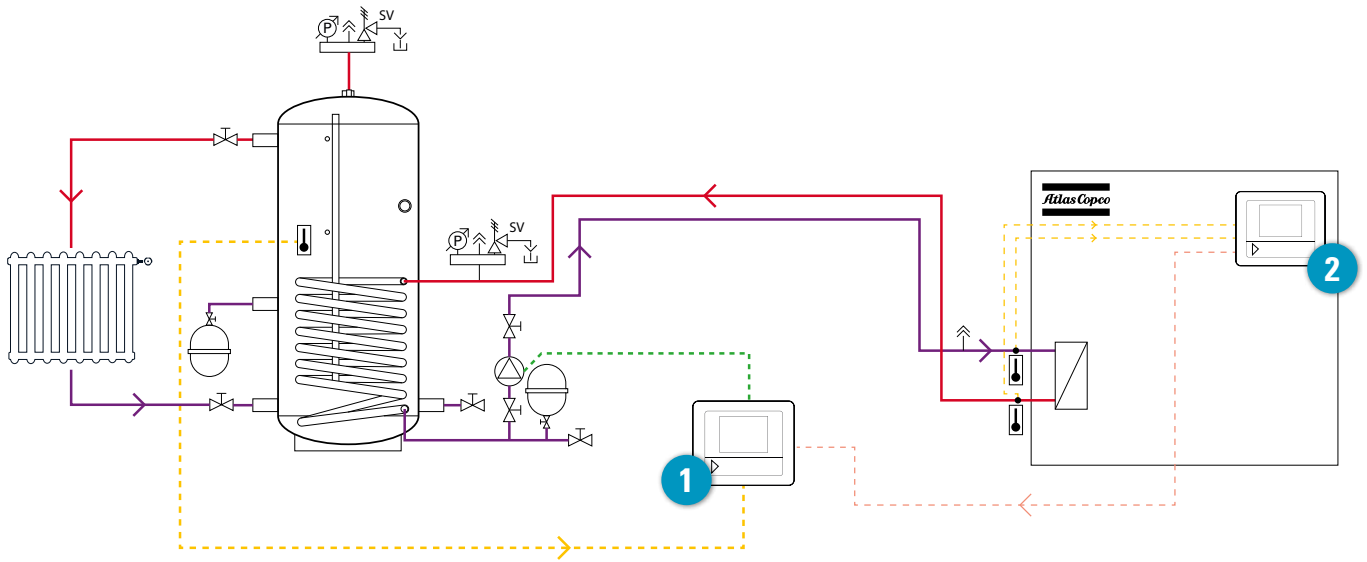

- 1 Central heating kit controller
- 2 Compressor controller
- Cold water
- Warm water

- CAN connection between controllers (1) and (2)
- Temperature measurement
- Temperature sensor

Wide range of applications

The Atlas Copco Thermo Kit is designed for domestic and office central heating systems. A 30 kW compressor for example has the potential to heat up a room of up to 300 m² (depending on the operation hours of the compressor).

This closed loop system stands for the highest degree of protection and is designed for general applications of central heating systems such as boilers and heat pumps, and various energy sources such as gas, oil, electricity, wood/biomass pellets and solar power. The 400 liter buffer vessel can be connected to Atlas Copco's GA 11-30, GA 30+-45+ and GA 18-37 VSD compressors; the 800 liter buffer vessel is suitable for GA 55-90 compressors. The buffer vessels comply with the latest (January 2015) ErP legislation.

Easy and quick to install

The Thermo Kit includes a buffer vessel, a circulation pump, a control box and all the parts necessary for safe and reliable connection of the energy recovery cooler of a compressor to a central heating system. It's simple to install. No engineering work is necessary and installation takes half a day at the most.

